

SCAMBIATORI DI CALORE TIPO ARIA-OLIO  
HEAT EXCHANGER AIR-OIL VERSION

CARATTERISTICHE TECNICHE DEL GRUPPO DI VENTILAZIONE  
TECHNICAL FEATURES

Tipologia Type	Frequenza Frequency Hz	Tensione Voltage V	Giri/min RPM N.°	Potenza Power kW	Ø ventola Ø FAN (mm)	dB (A)	Q air (m <sup>3</sup> /h)	Cap. (lt)	Peso Weight (kg)	IP
12	DC	12	3090	0.218	305	82.67	2617	1.5	14	68
24	DC	24	3090	0.218	305	82.67	2324	1.5	14	68

Portata olio consigliata da 20 a 70 (lt/min)  
Suggested oil flow from 20 to 70 (lt/min)

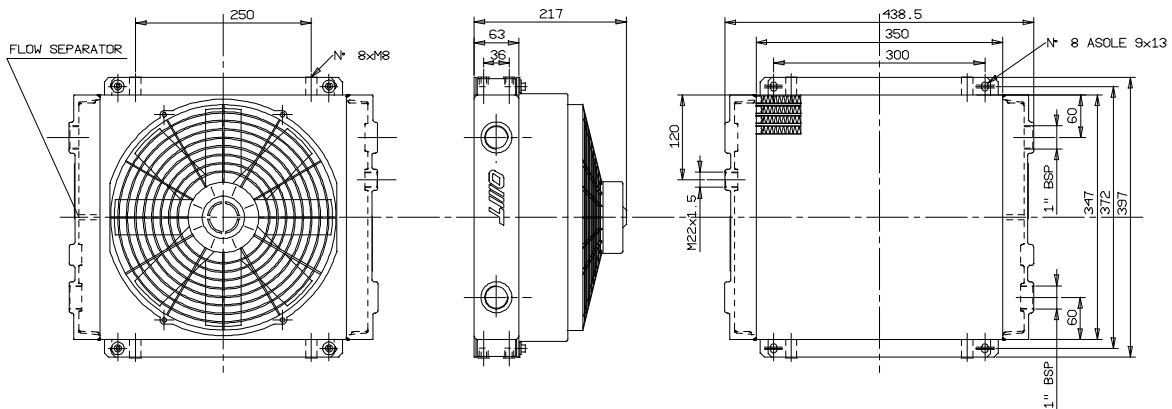

COEFFICIENTE DI CORREZIONE  
CORRECTION FACTOR

CST	10	15	20	32	40	50	60	80	100	200
F	0.51	0.66	0.76	1	1.22	1.4	1.6	1.9	2.1	3.4

DIAGRAMMA DI RENDIMENTO  
PERFORMANCE DIAGRAM

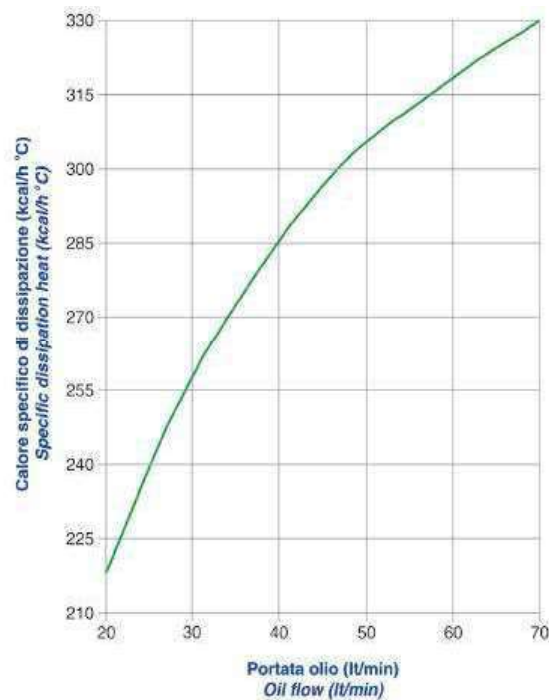

DIAGRAMMA PERDITE DI CARICO (32 cst)  
PRESSURE DROP DIAGRAM (32 cst)

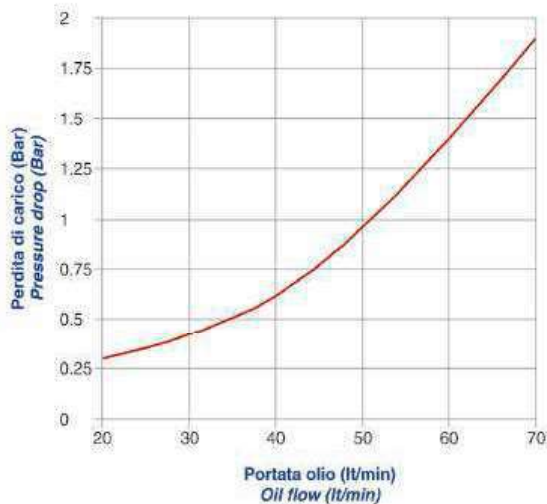

Le dimensioni di ingombro e le caratteristiche tecniche non sono impegnative  
Over-all dimensions and technical characteristic are not binding