

SCAMBIATORI DI CALORE TIPO ARIA-OLIO
HEAT EXCHANGER AIR-OIL VERSION

CARATTERISTICHE TECNICHE DEL GRUPPO DI VENTILAZIONE
TECHNICAL FEATURES

Tipologia Type	Frequenza Frequency Hz	Tensione Voltage V	Giri/min RPM N.°	Potenza Power kW	Ø ventola Ø FAN (mm)	dB (A)	Q air (m ³ /h)	Cap. (lt)	Peso Weight (kg)	IP
12	DC	12	2248	0.151	385	77	2950	2.6	26	68
24	DC	24	2248	0.151	385	77	3101	2.6	26	68

Portata olio consigliata da 80 a 260 (lt/min)
Suggested oil flow from 80 to 260 (lt/min)

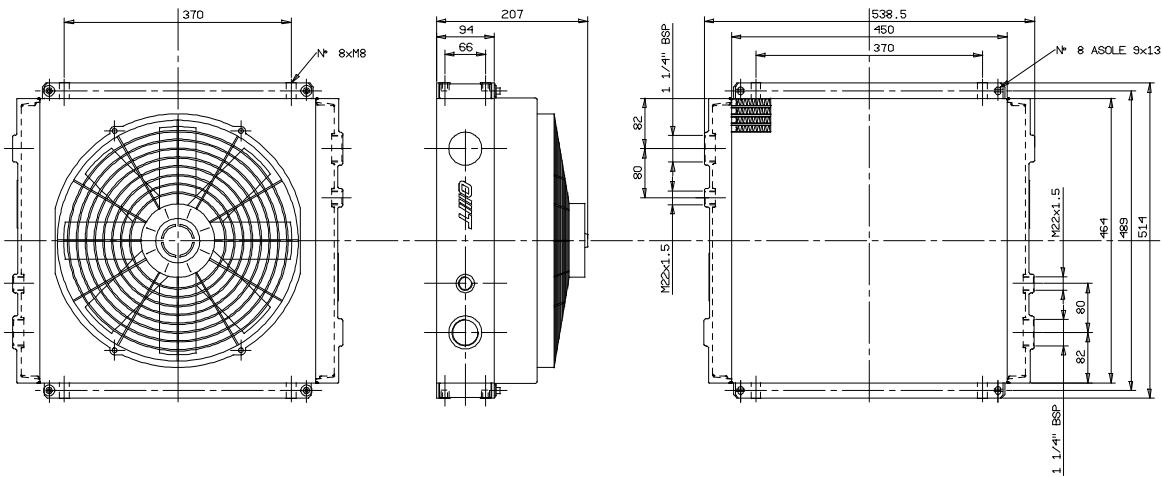

COEFFICIENTE DI CORREZIONE
CORRECTION FACTOR

CST	10	15	20	32	40	50	60	80	100	200
F	0.51	0.66	0.76	1	1.22	1.4	1.6	1.9	2.1	3.4

DIAGRAMMA DI RENDIMENTO
PERFORMANCE DIAGRAM

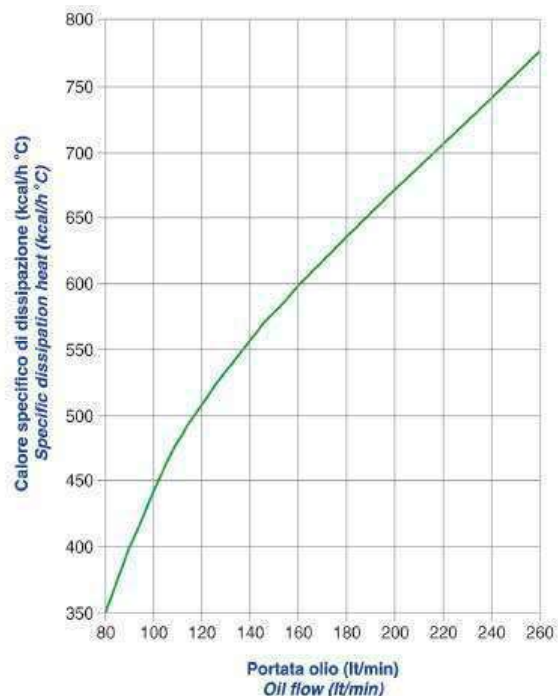

DIAGRAMMA PERDITE DI CARICO (32 cst)
PRESSURE DROP DIAGRAM (32 cst)

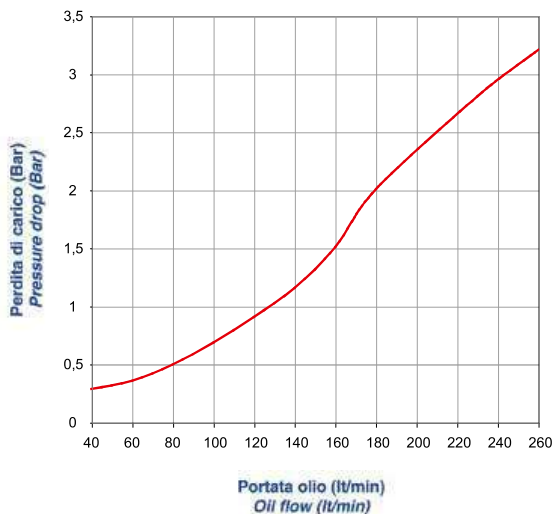

Le dimensioni di ingombro e le caratteristiche tecniche non sono impegnative
Over-all dimensions and technical characteristic are not binding