

SCAMBIATORE TIPO ARIA-OLIO
HEAT EXCHANGER AIR-OIL VERSION

CARATTERISTICHE TECNICHE DEL GRUPPO DI VENTILAZIONE
TECHNICAL FEATURES

Tipologia Type	Frequenza Frequency Hz	Tensione Voltage V	N° Giri/min RPM	Potenza Power kW	Diam. Ventola Ø FAN (mm)	dB (A)	L (mm)	Q air (m³/h)	Cap. (lt)	Peso Weight (kg)	IP
01	50/60	230	1380/1550	0.18/0.25	400	62	233	4000	2.6	21	44
03	50/60	380	1380/1520	0.18/0.25	400	70	233	4375	2.6	21	44
14	50	230/400	1390	0.55	400	71	438	4000	2.6	25	55
	60	276/480	1685	0.66							
12	DC	12	2248	0.151	385	77	206	2950	2.6	20	68
24	DC	24	2248	0.151	385	77	206	3101	2.6	20	68
G2	-	-	-	-	400	-	235.5	-	2.6	19	-

Portata olio consigliata da 40 a 160 (lt/min)
Suggested oil flow from 40 to 160 (lt/min)

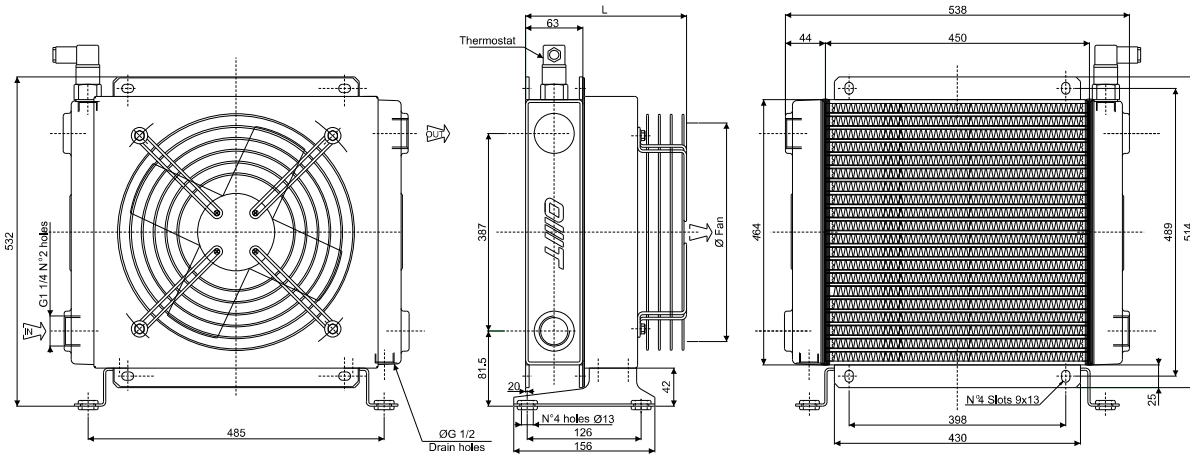

Coefficiente di correzione
Correction factor

CST	10	15	20	32	40	50	60	80	100	200
F	0.51	0.66	0.76	1	1.22	1.4	1.6	1.9	2.1	3.4

Diagramma di rendimento
Performance diagram

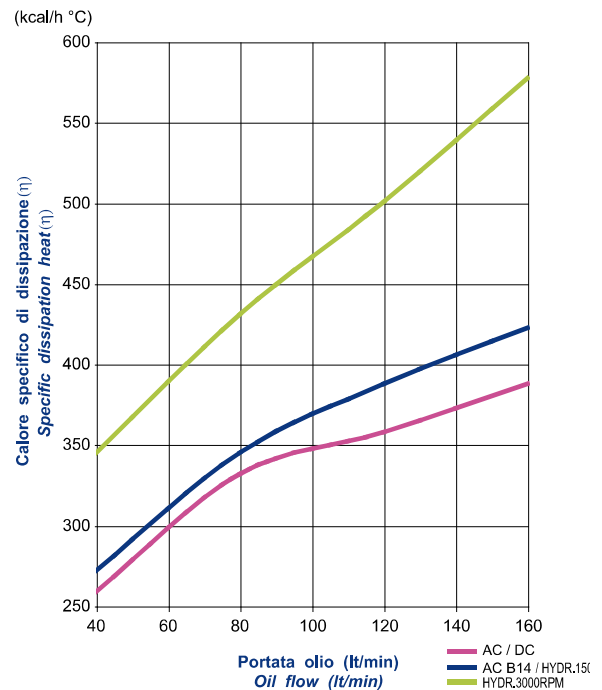

Diagramma perdite di carico (32 cst)
Pressure drop diagram (32 cst)

