

SCAMBIATORE TIPO ARIA-OLIO  
HEAT EXCHANGER AIR-OIL VERSION

CARATTERISTICHE TECNICHE DEL GRUPPO DI VENTILAZIONE  
TECHNICAL FEATURES

Tipologia Type	Frequenza Frequency Hz	Tensione Voltage V	N° Giri/min RPM	Potenza Power kW	Diam. Ventola Ø FAN (mm)	dB (A)	L (mm)	Q air (m³/h)	Cap. (lt)	Peso Weight (kg)	IP
01	50	220	2300	0.145/0.175	300	62	213	2200	1.5	15	54
03	50	380	2340	0.075/0.095	300	62	213	1910	1.5	15	54
14	50	230/400	1370	0.37	300	69	408	2000	1.5	20	55
	60	276/480	1640	0.44							
12	DC	12	3090	0.218	305	82	217	2617	1.5	14	68
24	DC	24	3090	0.218	305	82	217	2324	1.5	14	68
G2	-	-	-	-	300	-	226,5	-	1.5	14,5	-

Portata olio consigliata da 35 a 140 (lt/min)  
Suggested oil flow from 35 to 140 (lt/min)

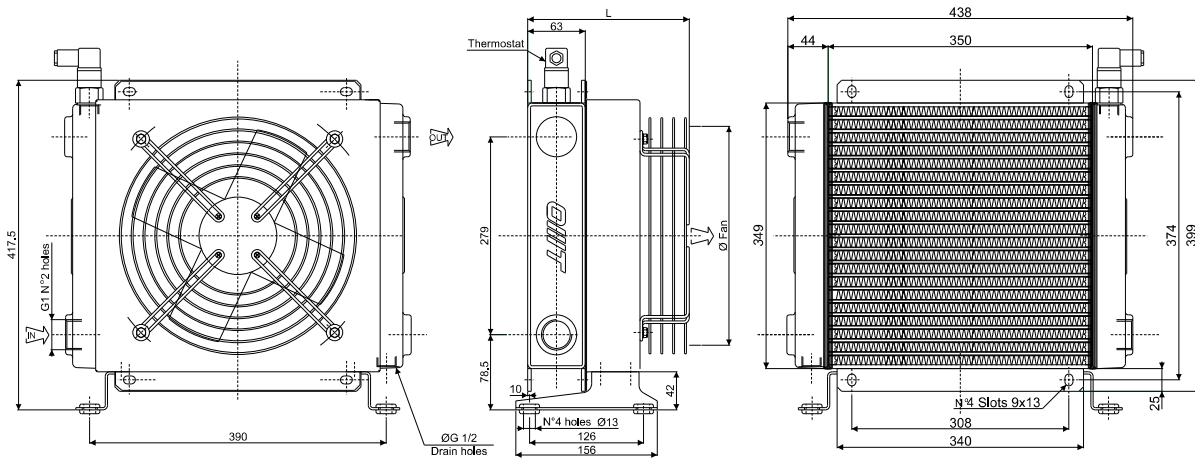

Coefficiente di correzione  
Correction factor

CST	10	15	20	32	40	50	60	80	100	200
F	0.51	0.66	0.76	1	1.22	1.4	1.6	1.9	2.1	3.4

Diagramma di rendimento  
Performance diagram

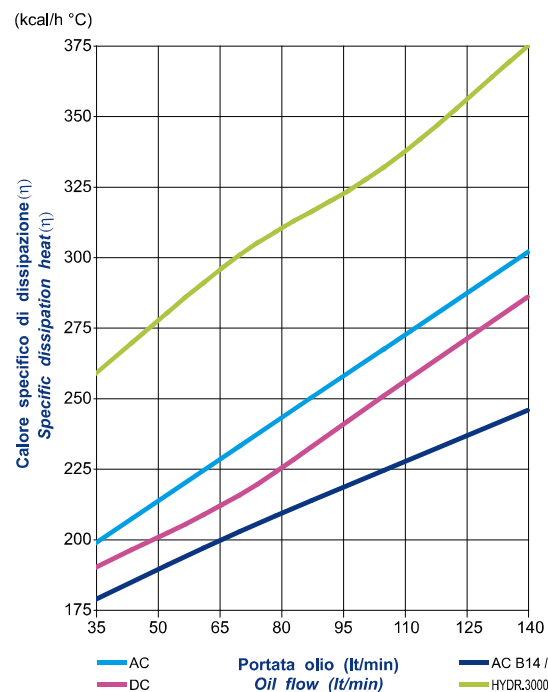

Diagramma perdite di carico (32 cst)  
Pressure drop diagram (32 cst)

