

FISSAGGIO AL SERBATOIO
FIXING ONTO TANK

PAM

Pompe a Mano
Hand Pumps

CODICE DI ORDINAZIONE / DECODING
PAM 015 XX 0 3 0

DOPPIO EFFETTO
DOUBLE ACTING

PAM-TDV12
PAM-TDV25
PAM-TDV45

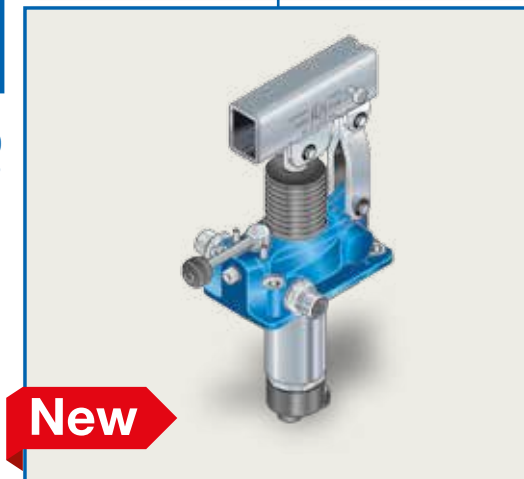
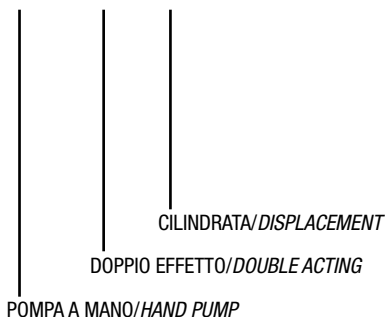



SERIE PAM

CARATTERISTICHE E DATI TECNICI / SPECIFICATIONS AND TECHNICAL DATA

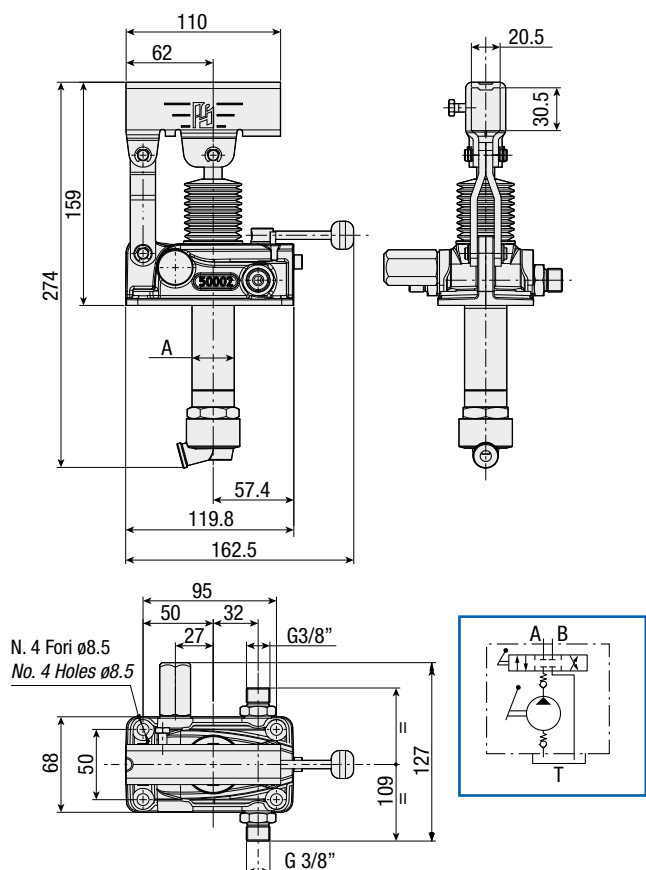
TIPO TYPE	CODICE CODE	CILINDRATA DISPLACEMENT cm ³ /ciclo cm ³ /cycle	PRESSIONE MAX MAX PRESSURE	A mm	PESO WEIGHT kg
PAM-TDV12	PAM01512030	12	380	Ø 30	2.96
PAM-TDV25	PAM01525030	25	350	Ø 35	3.07
PAM-TDV45	PAM01545030	45	280	Ø 40	3.20

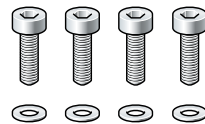

KIT RICAMBI PAM-TDV / PAM-TDV SPARE PARTS KIT

CODICE CODE	DESCRIZIONE DESCRIPTION
PAMJ0300180	Viti di fissaggio Fastening screws 
	Serrare a coppia Max 25 Nm ± 2 Tightening torque Max 25 Nm ± 2
	Guarnizione Gasket 

Le pompe a mano PAM-TDV vengono fornite complete di viti di fissaggio e guarnizione.
Hand Pumps of PAM-TDV series are supplied with fastening screws and seal.

LEVA E SERBATOIO OLIO FORNITI A RICHIESTA
LEVER AND OIL TANK SUPPLIED ON REQUEST