



DIPLOMATIC
HYDRAULICS

41 210/103 ED

MD1L

SOLENOID OPERATED DIRECTIONAL CONTROL VALVE IN COMPACT EXECUTION

SERIES 10



CETOP 03

p max 250 bar

Q max 40 l/min

MOUNTING INTERFACE

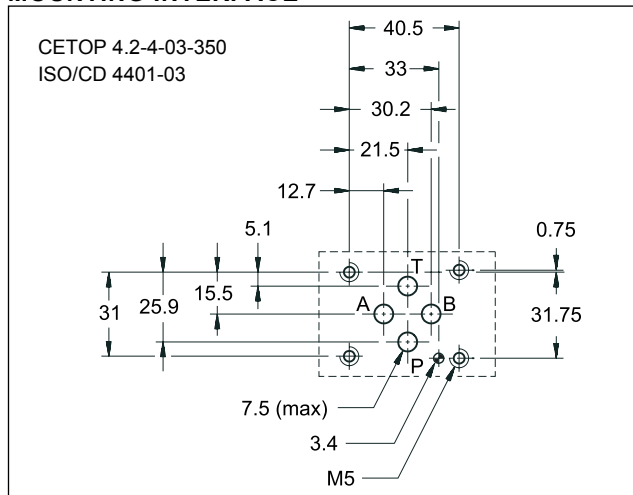

OPERATING PRINCIPLE

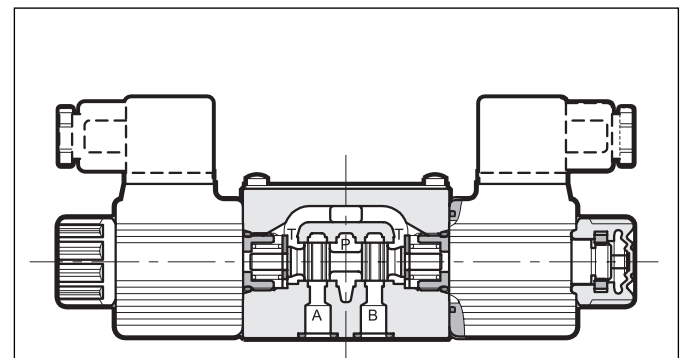

- Direct acting, subplate mounting directional control valve, with mounting surface according to CETOP RP121H - 4.2-4-03 and ISO 4401-03.

PERFORMANCE RATINGS (with mineral oil of viscosity of 36 cSt at 50°C)

Maximum working pressure Ports P - A - B - T	bar	250
Maximum flow	l/min	40
Pressure drop $\Delta p-Q$	see par. 4	
Operating limits	see par. 5	
Electrical features	see par. 6	
Electrical connections	see par. 9	
Ambient temperature range	°C	-20 ÷ +50
Fluid temperature range	°C	-20 ÷ +80
Fluid viscosity range	cSt	10 ÷ 400
Recommended viscosity	cSt	25
Fluid contamination degree	according to NAS 1638 class 10	
Mass:		
single solenoid valve	kg	1,15
double solenoid valve	kg	1,42

- Compact design with reduced solenoid dimensions, suitable for mini-powerpacks and mobile and agricultural applications.
- The valve body is made with high strength iron castings provided with wide internal passages in order to minimize the flow pressure drop. Wet armature solenoids with interchangeable coils are used (for further information on solenoids see par. 6).
- The valve is supplied with 3 or 4 way designs and with several interchangeable spools with different porting arrangements.
- The valve is available with DC or rectified current solenoids and with four different types of electrical connections in order to cover many installation requirements (see par. 9).
- It is normally supplied with boot protected manual override which ensures IP65 protection degree.



1 - IDENTIFICATION CODE

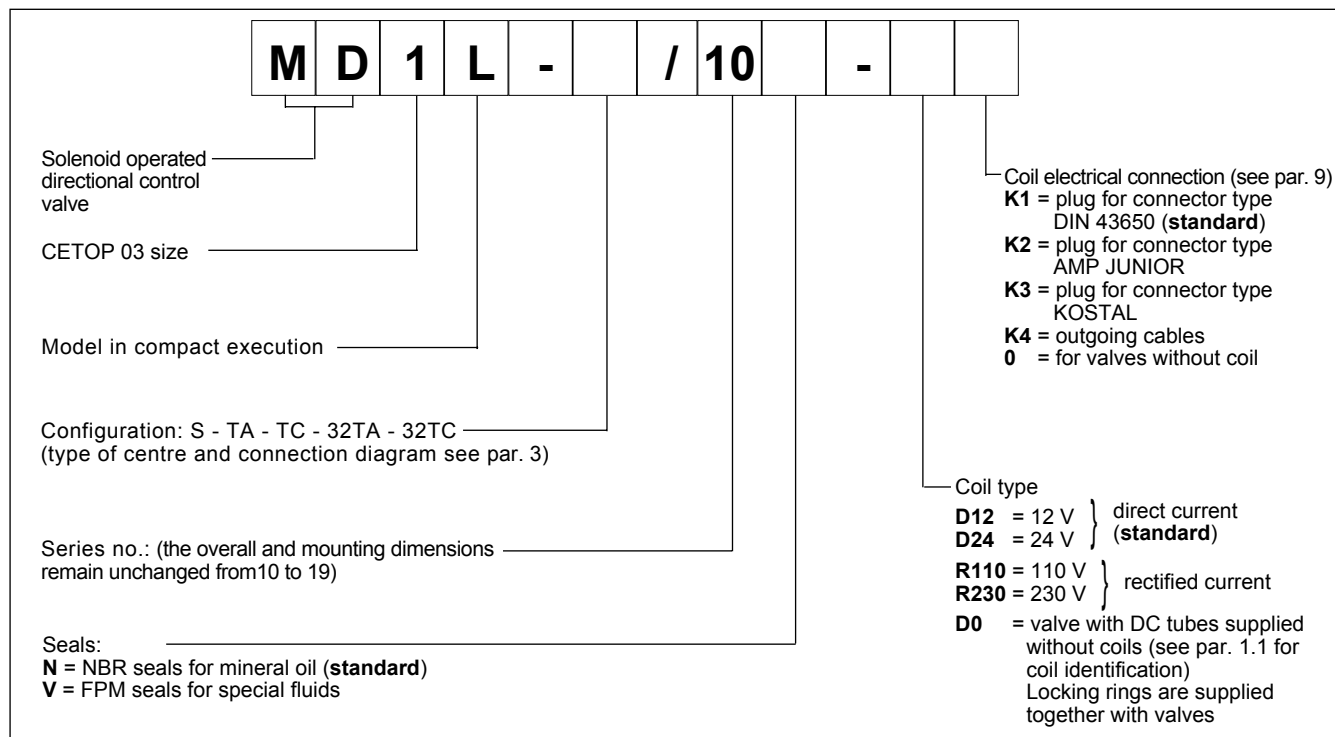

NOTE: The standard valve is supplied with phosphating surface treatment, black colour.
 Upon request this valve can be supplied with black epoxy painting (add /P at the end of identification code).

1.1 - COILS IDENTIFICATION CODE

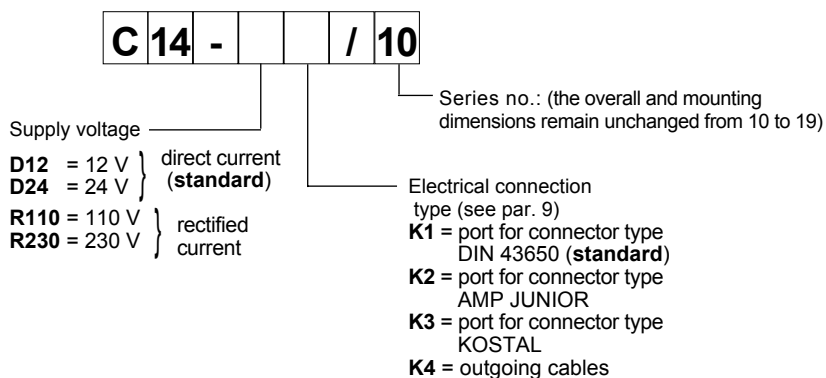

2 - HYDRAULIC FLUIDS

Use mineral oil-based hydraulic fluids HL or HLP type, according to ISO 6743/3.
 For fluids HFD-R type (phosphate esters) use FPM seals (code V).
 For the use of other fluid types such as HFA, HFB, HFC, please consult our technical department.

Using fluids at temperatures higher than 70°C causes a faster degradation of the fluid and of the seals characteristics.
 The fluid must be preserved in its physical and chemical characteristics.



3 - CONFIGURATIONS

Type S:
2 solenoids - 3 positions
spring centering

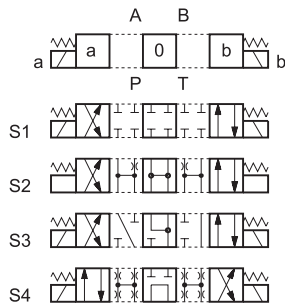

Type *TA:
1 solenoid side A
2 positions (central + external)
spring centering

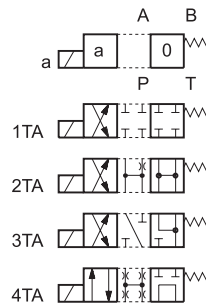

Type *TC:
1 solenoid side B
2 positions (central + external)
spring centering

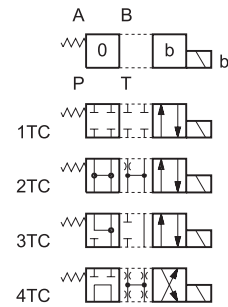

Type TA:
1 solenoid side A - 2 external positions
with return spring

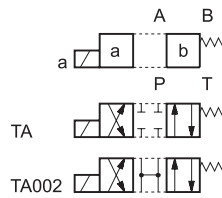

Type TC:
1 solenoid side B - 2 external positions
with return spring

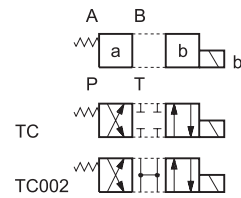

Type 32TA / 32TC

3 way valve - 1 solenoid - 2 external positions, return spring

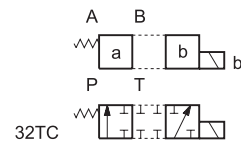
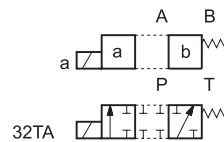

N.B.: Other spool types available
upon request



4 - PRESSURE DROPS Δp -Q (obtained with viscosity of 36 cSt at 50 °C)

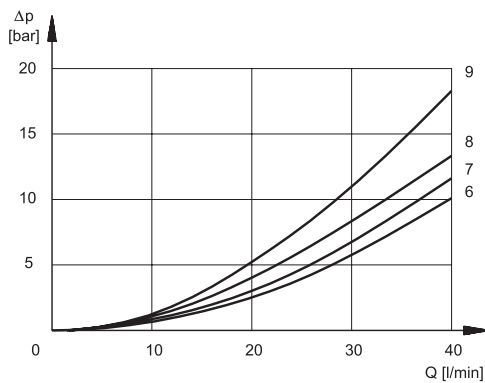
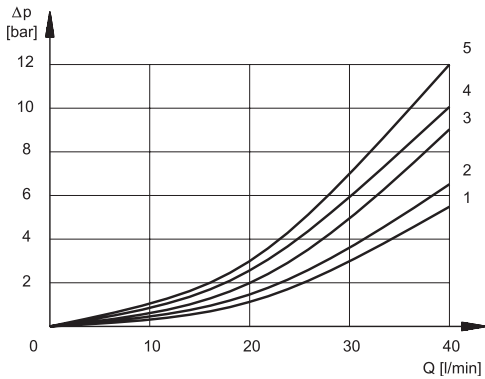

SPOOL	SPOOL POSITION	CONNECTIONS				
		P→A	P→B	A→T	B→T	P→T
		CURVES ON GRAPH				
S1, 1TA, 1TC	Energized	3	3	5	5	
S2, 2TA, 2TC	De-energized	2	2	1	1	2*
	Energized					
S3, 3TA, 3TC	De-energized			4*	4 ^o	
	Energized	3	3	1	1	
S4, 4TA, 4TC	De-energized					8
	Energized	9	9	9	9	
TA, TC	De-energized					
	Energized	6	6	6	6	
32TA, 32TC	De-energized					
	Energized	7	7	7	7	

* A-B blocked ■ B blocked ° A blocked

5 - OPERATING LIMITS

The curves define the flow rate operating fields according to the solenoid valve pressure with DC and AC rectified solenoids. The values have been obtained with viscosity 36 cSt, temperature 50 °C, filtration 25 μm and with solenoids at 140°C coil temperature and supplied with voltage equal to 90% of the nominal voltage.

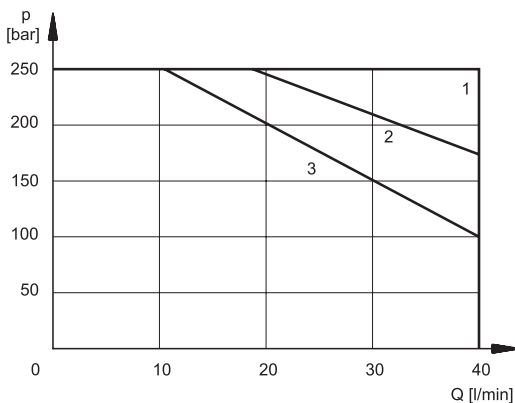

curve	spool type	curve	spool type
1	S1, 1TA, 1TC	3	S3, 3TA, 3TC
2	S2, 2TA, 2TC	3	S4, 4TA, 4TC
2	32TA, 32TC		

The values indicated in the graph can be considerably reduced if a 4-way valve is used with port A or B plugged.

5.1 Switching times

The values indicated refer to an S1 solenoid valve for Q=25 l/min, p=150 bar working with mineral oil at a temperature of 50°C, a viscosity of 36 cSt and with PA and BT connections. The energizing times are obtained at the time the spool switches over. The de-energizing times are measured at the time pressure variation occurs on the line.

TIMES (±10%)	
ENERGIZING	DE-ENERGIZING
100 ms	50 ms



6 - ELECTRICAL FEATURES

6.1 Solenoids

These are essentially made up of two parts: tube and coil. The tube is threaded onto the valve body and includes the armature that moves immersed in oil, without wear. The inner part, in contact with the oil in the return line, ensures heat dissipation.

The coil is fastened to the tube by a threaded nut, and can be rotated 360°, compatible with the available space.

The interchangeability of coils of different voltages both D or R type is possible without removing the tube.

SUPPLY VOLTAGE FLUCTUATION	± 10% Vnom	
MAX SWITCH ON FREQUENCY	10.000 ins/hr	
DUTY CYCLE	100%	
ELECTROMAGNETIC COMPATIBILITY (EMC)	in compliance with	
EMISSIONS (see note 1)	EN 50081-1	89/336 EEC
IMMUNITY	EN 50082-2	
LOW VOLTAGE	in compliance with	
	73/23/EEC	
	96/68/EEC	
Class of protection according to IEC 144	IP 65	
Atmospheric agents	class H	
Coil insulation	class H	
Impregnation	class H	

Note 1: In order to further reduce the emissions, use of type H connectors (for DC supply) is recommended. These prevent voltage peaks on opening of the coil supply electrical circuit (see CAT. 49 000).

6.2 Current and absorbed power

In the table are shown current and power consumption values relevant to the different coil types. "R" coil must be used when the valve is fed with AC power supply subsequently rectified by means of rectifier bridge, externally or incorporated in the "D" type connector (see cat. 49 000).

Coil type	Resistance at 20°C [Ω] ± 1%	Current consumption A (± 5%)	Power (± 5%)	
			W	VA
C14-D12*	5,4	2,2	26,5	
C14-D24*	20,7	1,16	27,8	
C14-R110*	363	0,25		27,2
C14-R230*	1640	0,11		26,4



7 - OVERALL AND MOUNTING DIMENSIONS

3 POSITION EXECUTION MD1L - S*

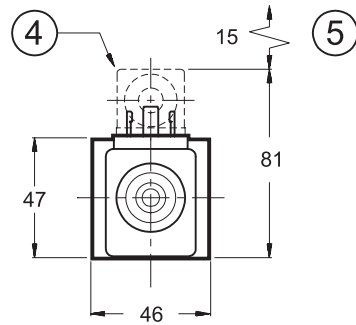
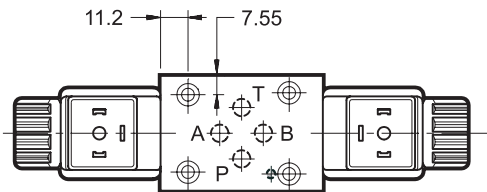
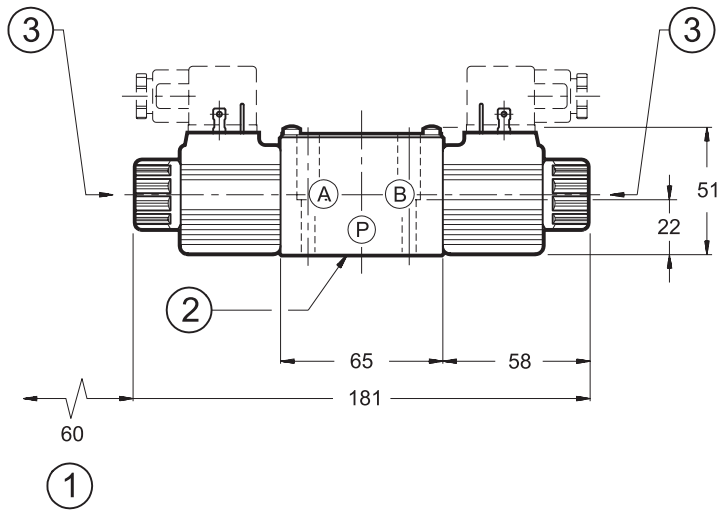

2 POSITION EXECUTION MD1L - TA, MD1L-*TA, MD1L-32TA

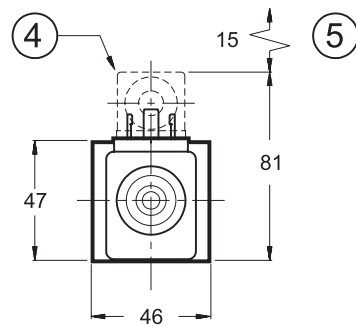
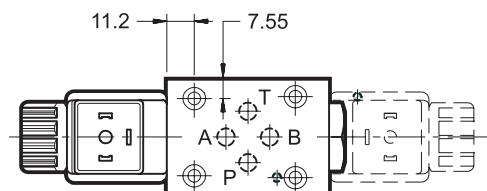
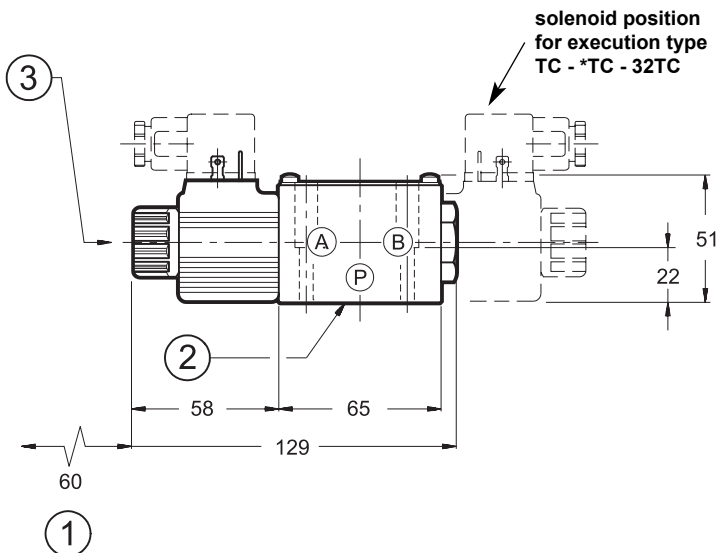

dimensions in mm

1	Coil removal space
2	Mounting surface with sealing rings
3	Locking ring with boot protected manual override
4	DIN 43650 electrical connector (representation with K1 standard connection - see par. 9 for other connection types)
5	Connector removal space

See par. 11 for fastening bolts and sealing rings



8 - INSTALLATION

The configuration with centering and return springs can be mounted in any position. Valve fitting takes place by means of screws or tie rods, fixing the valve on a lapped surface, with values of planarity and smoothness that are equal to or better than those indicated in the drawing. If the minimum values of planarity or smoothness are not met, fluid leakages between valve and mounting surface can easily occur.

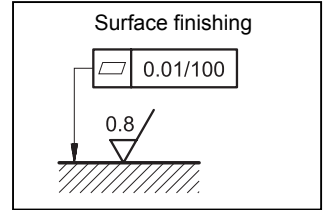

9 - ELECTRIC CONNECTORS

connection for DIN 43650
connector type
code **K1 (standard)**

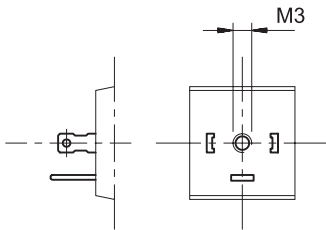

connection for AMP JUNIOR
connector type
code **K2**

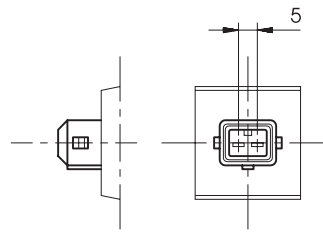

connection for KOSTAL
connector type
code **K3**

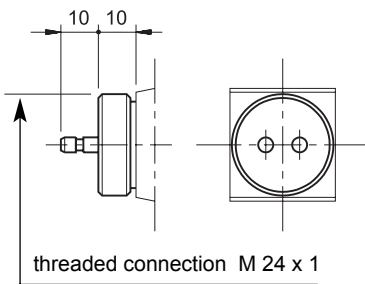

outgoing cable connections
code **K4**

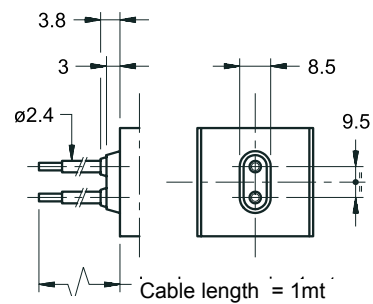



10 - ELECTRIC CONNECTORS

The solenoid valves are supplied without connectors.

For coils with standard electrical connections K1 type (DIN 43650) the connectors can be ordered separately.

For the identification of the connector type to be ordered please see cat. 49 000.

For K2 and K3 connection type the relative connectors are not available.

11 - FASTENING BOLTS AND SEALING RINGS

Single valve fastening: 4 screws M5x30
Tightening torque: 5 Nm
Threads of mounting holes: M5x10
Sealing rings: N. 4 OR tipo 2037 - 90 shore

12 - SUBPLATES (See catalogue 51 000)

Type PMMD-AI3G with rear ports
Type PMMD-AL3G with side ports
P, T, A, B port dimensions: 3/8" BSP

	DIPLOMATIC OLEODINAMICA SpA 20025 LEGNANO (MI) - P.le Bozzi, 1 / Via Edison Tel. 0331/472111-472236 - Fax 0331/548328	
--	--	--