

Valvola di blocco e controllo portata per bracci, montaggio in linea, versione destra
Flow check and metering valve for booms, line mounted, right version

Rev.02-2010/09

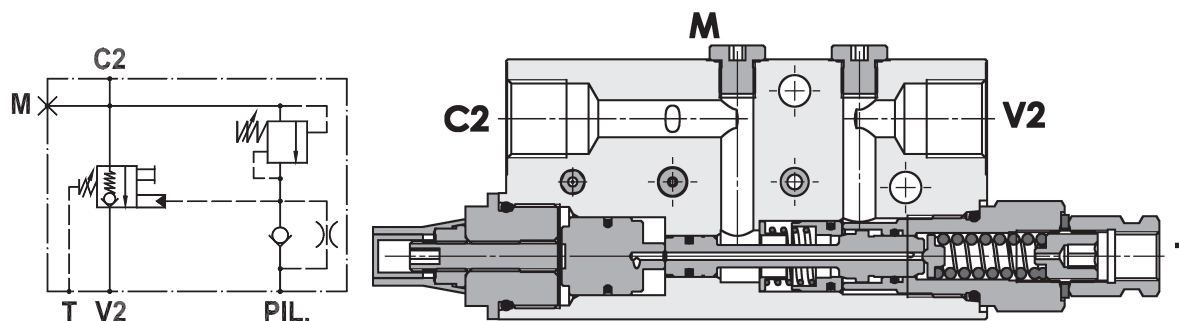

SPECIFICHE TECNICHE

Materiali: corpo in acciaio zincato. I componenti interni sono in acciaio trattato termicamente.

Portata max.: 100 l/min

Pressione max.: 420 bar

Regolazione pressione: mediante vite

Campo di regolazione pressione: vedere pag.02

Peso: 2.500 Kg

TECHNICAL SPECIFICATIONS

Materials: body is in steel zinc plated. Internal parts are in hardened steel.

Rated flow: up to 100 l/min

Max. setting: 420 bar

Adjustment means: leakproof screw adjustment

Adjustable pressure range: see page 02

Weight: 2.500 Kg

DIAGRAMMA PERDITE DI CARICO - PRESSURE DROP CURVES

Viscosità olio 24 mm²/sec. (3,5 °E)
 Temperatura 50 °C

Oil viscosity 24 mm²/sec. (3,5 °E)
 Temperature 50 °C

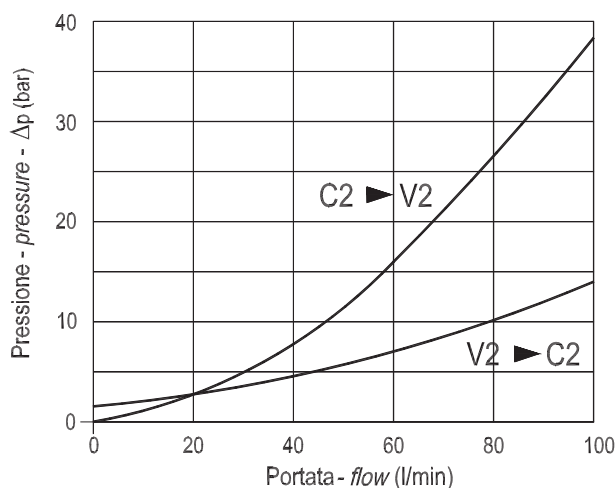

Valvola di blocco e controllo portata per bracci, montaggio in linea, versione destra
Flow check and metering valve for booms, line mounted, right version

Rev.02-2010/09

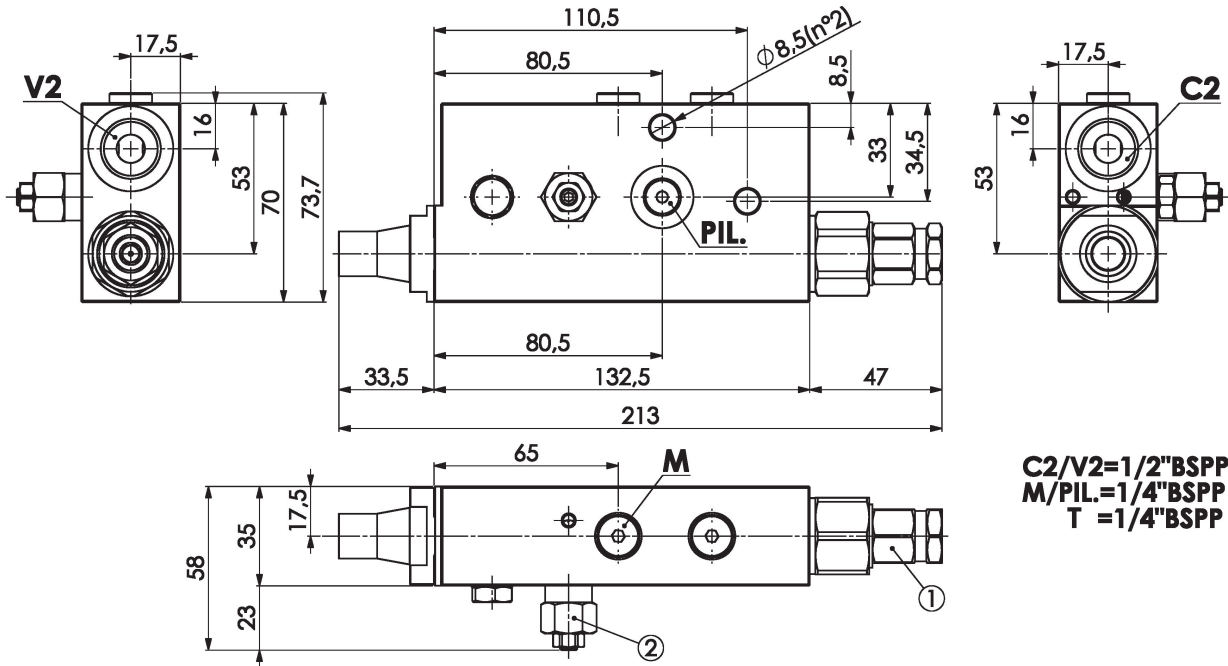

C2/V2=1/2"BSPP
M/PIL.=1/4"BSPP
T =1/4"BSPP

MOLLA VALVOLA (1) - SPRING VALVE (1)

Codice Code	Campo taratura min.-max. bar Adjustable pressure range bar	Incres. press. bar/giro vite Pressure increase bar/turn	Taratura standard bar Standard setting bar
05	3 - 14	2.5	7.5

MOLLA VALVOLA (2) - SPRING VALVE (2)

Codice Code	Campo taratura min.-max. bar Adjustable pressure range bar	Incres. press. bar/giro vite Pressure increase bar/turn	Taratura standard bar Standard setting bar
50	250 - 500	198	350

ESEMPIO DI ORDINAZIONE - ORDERING CODE EXAMPLE

F P E X C **9 0** **S** **1 / 2** **L** **D X** **0 5** **5 0**